

STRUCTURALLY CERTIFIED

ITEM NO.	QTY.	DESCRIPTION	MATERIAL
1	1	HIGH VIBRATION POLE TOP - THREADED	STEEL / HOT-DIP GALVANIZED
2	1	Maxis™ M1 Joint	STEEL / HOT-DIP GALVANIZED
3	1	BASE POLE SECTION - CONDUITS c/w REDUCER	STEEL / HOT-DIP GALVANIZED

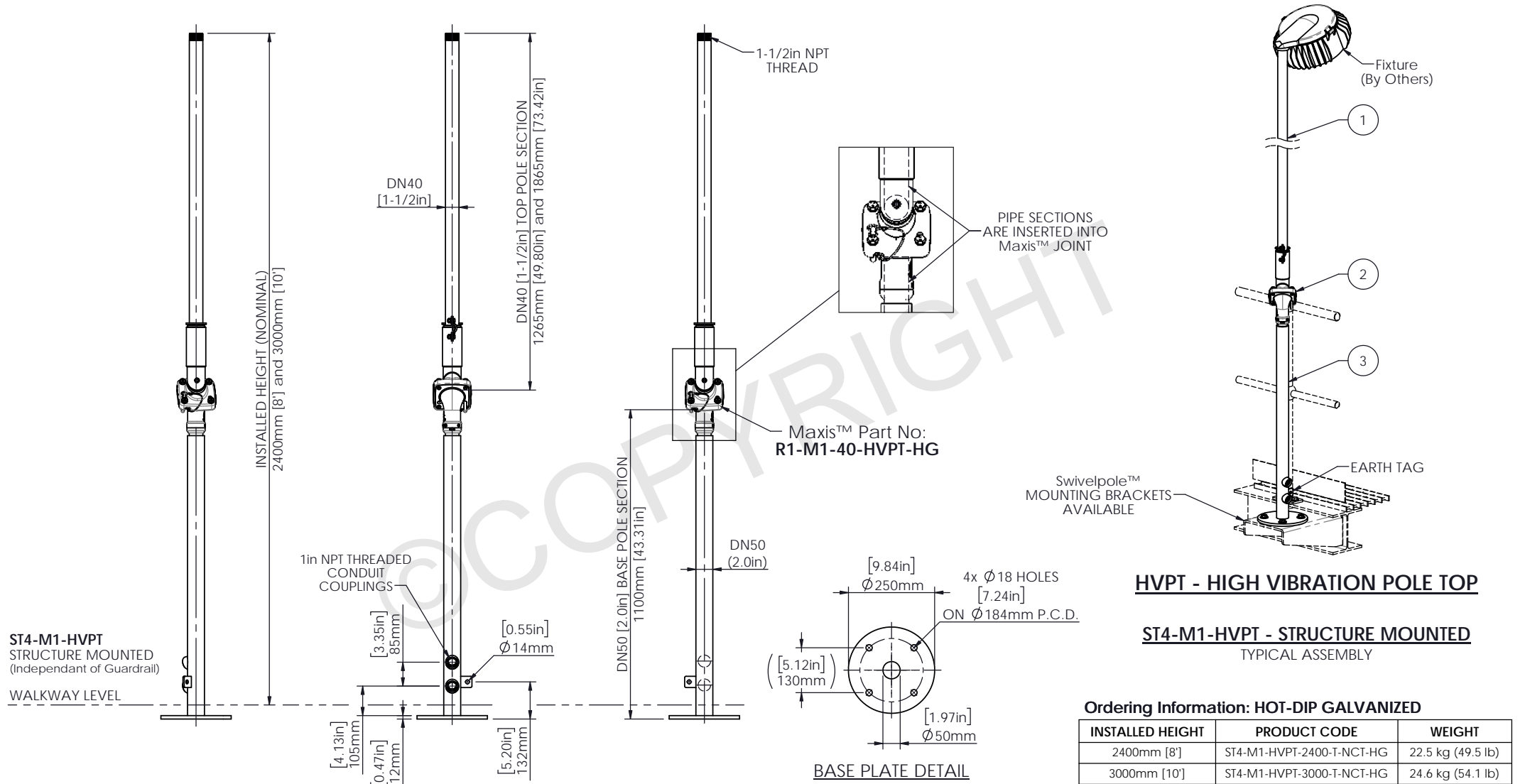

Ordering Information: HOT-DIP GALVANIZED

INSTALLED HEIGHT	PRODUCT CODE	WEIGHT
2400mm [8']	ST4-M1-HVPT-2400-T-NCT-HG	22.5 kg (49.5 lb)
3000mm [10']	ST4-M1-HVPT-3000-T-NCT-HG	24.6 kg (54.1 lb)



Scan Code with OR Reader app for more Maxis™ Product Solutions

maxis
PATENTED
PRODUCTS

www.maxisjoint.com

PATENTED
PRODUCTS

www.swivelpole.com

Swivelpole

This document is the property of and protected by copyright owned by Swivelpole Group Pty Ltd and or Exemplar Products Pty Ltd. The designs and other information embodied in this document comprise confidential information of Swivelpole Group Pty Ltd and or Exemplar Products Pty Ltd and form part of products covered by international patents and registered designs including US patent No 6957832 and US patent No 9945143. Unauthorised use, reproduction and disclosure are strictly prohibited. This document must not be removed from the premises of the licensed user of this document without Swivelpole Group Pty Ltd's and or Exemplar Products Pty Ltd's prior approval.

ALL DIMENSIONS ARE IN MILLIMETERS / INCHES		SERIES / CODE	PART NUMBER
DRAWN BY: BP		ST-HVPT	As Noted
CHECKED BY: KM		DATE: 01/02/23	TITLE: Swivelpole™ ST4 - Maxis™ M1
APPROVED BY: AI		DATE: 02/02/23	Base Section - CONDUITS - HVPT Top Section - THREADED
THIRD ANGLE PROJECTION		DATE: 03/02/23	General Assembly
SCALE: N.T.S.		DRG No: C-NEC-ST4-M1-HVPT-5040-T-NCT-HG	REV: 0
			A3

NEC