

ITEM No.	QTY.	DESCRIPTION	MATERIAL OPTIONS
1	1	TOP POLE SECTION - THREADED	STEEL / HOT DIP GALVANIZED
2	1	Maxis™ M1 JOINT	STEEL / HOT DIP GALVANIZED
3	1	BASE POLE SECTION - CONDUITS c/w REDUCER	STEEL / HOT DIP GALVANIZED

STRUCTURALLY CERTIFIED

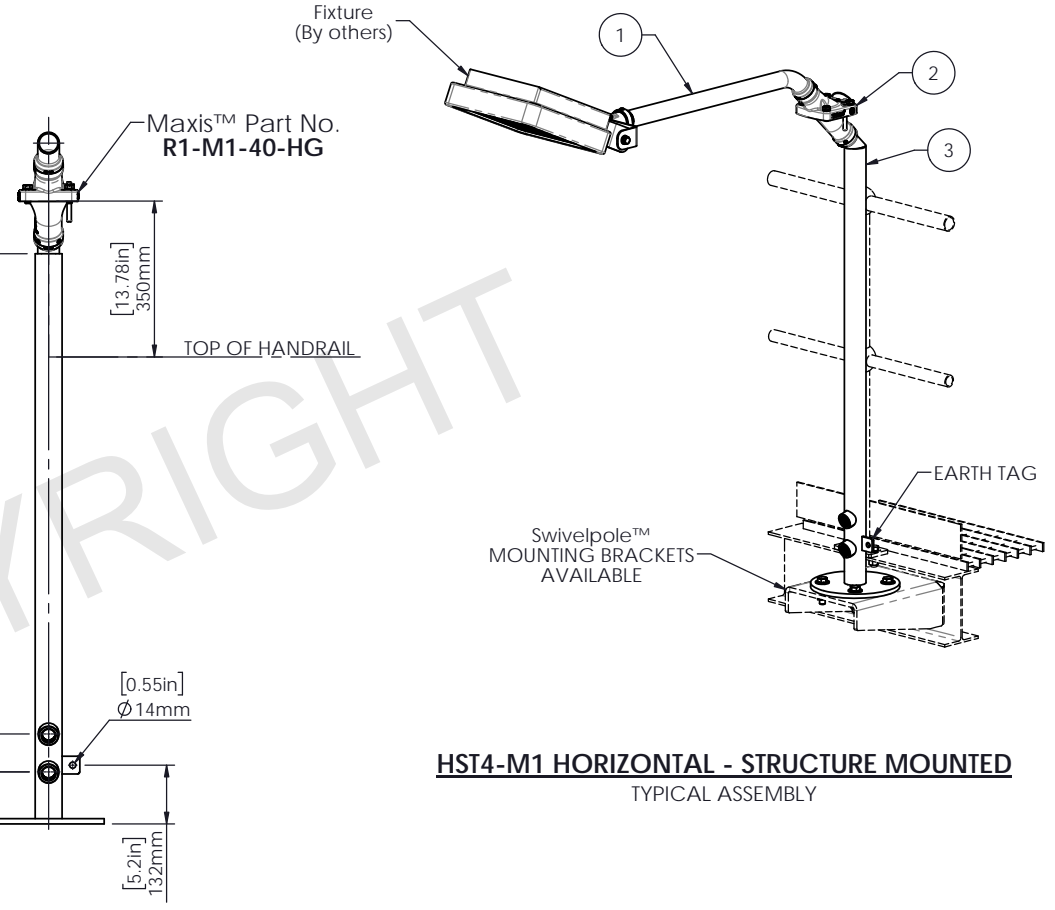
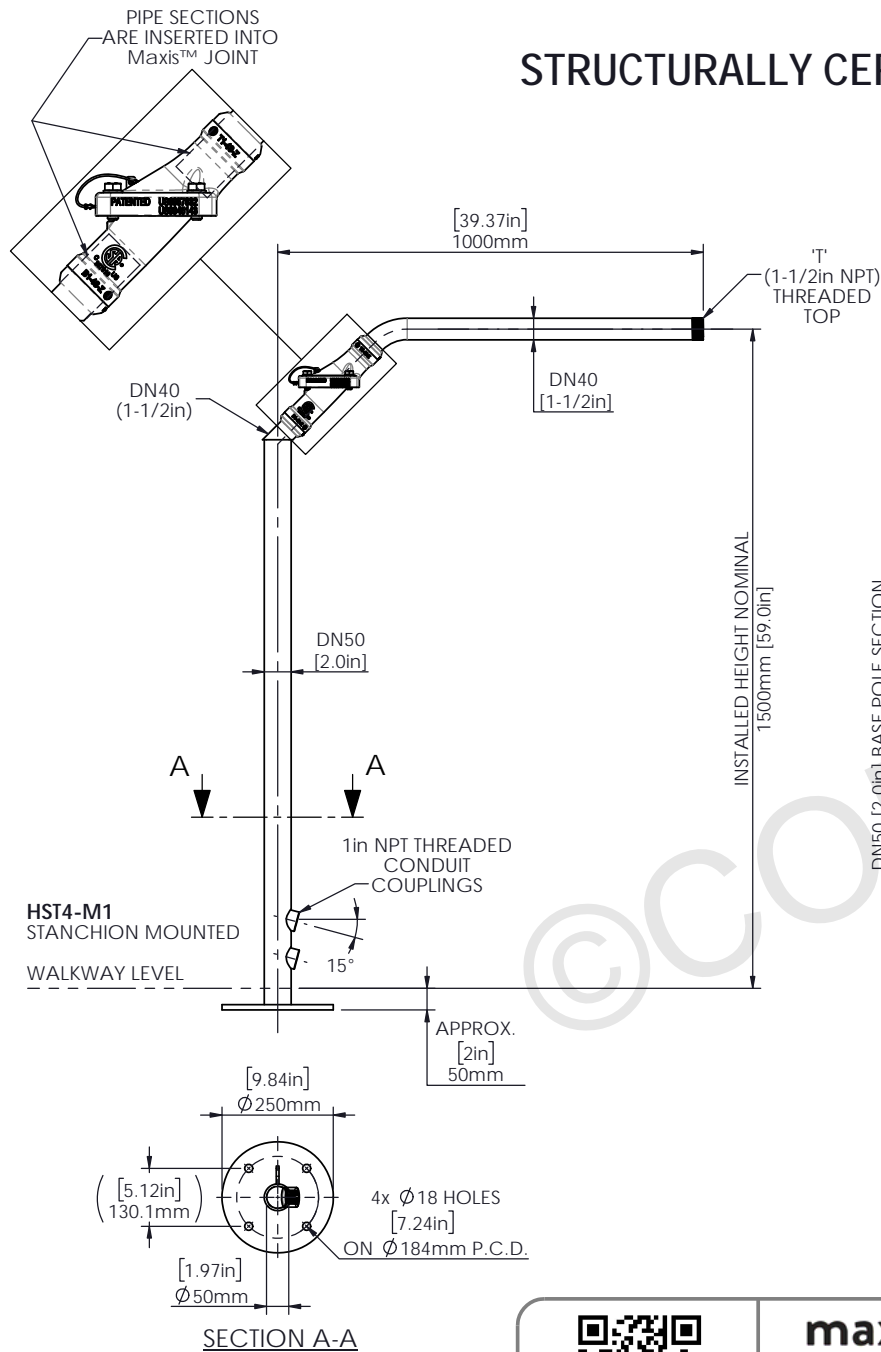

Ordering Information: HOT-DIP GALVANIZED

INSTALLED HEIGHT	PRODUCT CODE	WEIGHT
1500mm [5']	HST4-M1-1500-10-T-NCT-HG	22.0 kg (48.4 lb)

NEC



Scan Code with QR Reader app for more Swivelpole™ - Maxis™ Product Information

maxis
PATENTED PRODUCTS

www.maxisjoint.com

PATENTED
PRODUCTS

www.swivelpole.com

Swivelpole

This document is the property of and protected by copyright owned by Swivelpole Group Pty Ltd and/or Exemplar Products Pty Ltd. The designs and other information embodied in this document comprise confidential information of Swivelpole Group Pty Ltd and/or Exemplar Products Pty Ltd and form part of products covered by international patents and registered designs including US patent No 6957832 and US patent No 9945143. Unauthorised use, reproduction and disclosure are strictly prohibited. This document must not be removed from the premises of the licensed user of this document without Swivelpole Group Pty Ltd's and/or Exemplar Products Pty Ltd's prior approval.

ALL DIMENSIONS ARE IN MILLIMETERS / INCHES		SERIES / CODE	PART NUMBER
DRAWN BY BP		HORIZ	As Noted
CHECKED BY KM		DATE 02/02/23	Swivelpole™ HST4 - Maxis™ M1 Horizontal DN50 BASE - Conduits with Spigot, DN40 TOP - Threaded Pole Client Detail
APPROVED BY AI		DATE 03/02/23	
THIRD ANGLE PROJECTION		DATE 03/02/23	
SCALE		N.T.S.	DRG No C-NEC-HST4-M1-1500-10-T-NCT-HG
			REV 0 A3