

SECURITY COVER
P/No: SC-PL2-HG ¹

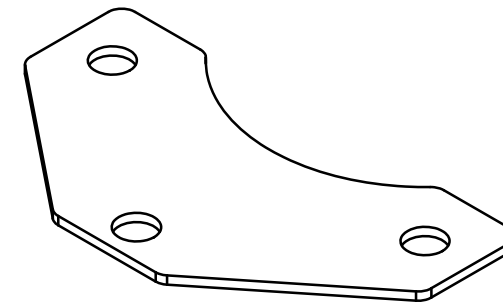

LOCKING PLATE
P/No: SC-PL1-HG ¹

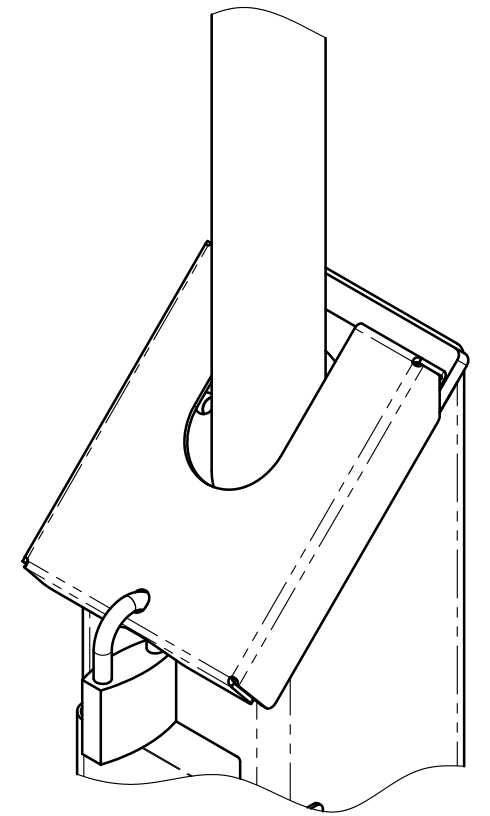

ISOMETRIC VIEW
F12 INSTAL SHOWN - Typical

SCALE 1 : 4

OPTIONAL ITEM FOR FREESTANDING SQUARE BASE SWIVELPOLES USED IN HIGH THEFT RISK AREAS

REV.	DESCRIPTION	DATE	APPROVED
2	UPDATED BASE SHOWN, ASSY STANDARDISED FOR AU & NA	16-08-12	PP
1	VIEWS REVISED TO SHOW NEW LOCKING PLATE & COVER	28-11-11	PP
0	ISSUED FOR MANUFACTURE.	31-03-10	PP
	REVISION HISTORY		

Swivelpole™

This document is the property of and protected by copyright owned by Safe Swivel Technology Pty Ltd (SST). The designs and other information embodied in this document comprise confidential information of SST and form part of products covered by international patents and registered designs including US patent No 6957832. Unauthorised use, reproduction and disclosure are strictly prohibited. This document must not be removed from the premises of the licensed user of this document without SST's prior approval.			
ALL DIMENSIONS ARE IN MILLIMETERS	PROJECT SWIVELPOLE	SERIES / CODE F	PART NUMBER As Shown
DRAWN BY AFFLATUS DESIGN	DATE 14-02-10	TITLE Swivelpole - Freestanding & Structure ¹	
CHECKED BY FB	DATE 22-03-10	Security cover	
APPROVED BY PP	DATE 31-03-10	General assembly	
THIRD ANGLE PROJECTION	SCALE 1:2	DRG No C-AA-SC-001-HG	REV 2
			A3