

STRUCTURALLY CERTIFIED

| ITEM NO. | QTY. | DESCRIPTION | MATERIAL OPTIONS |
|----------|------|------------------------------|-------------------------------------|
| 1 | 1 | TOP POLE SECTION - THREADED | STEEL / HOT-DIP GALVANIZED ALUMINUM |
| 2 | 1 | Maxis™ M1 Joint | STEEL / HOT-DIP GALVANIZED |
| 3 | 1 | BASE POLE SECTION - THREADED | STEEL / HOT-DIP GALVANIZED ALUMINUM |

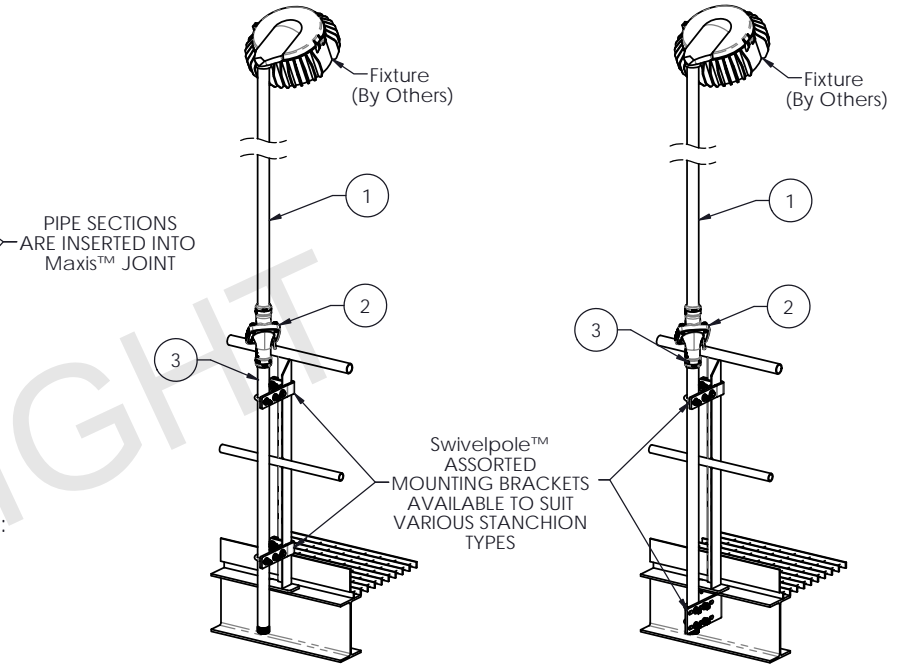
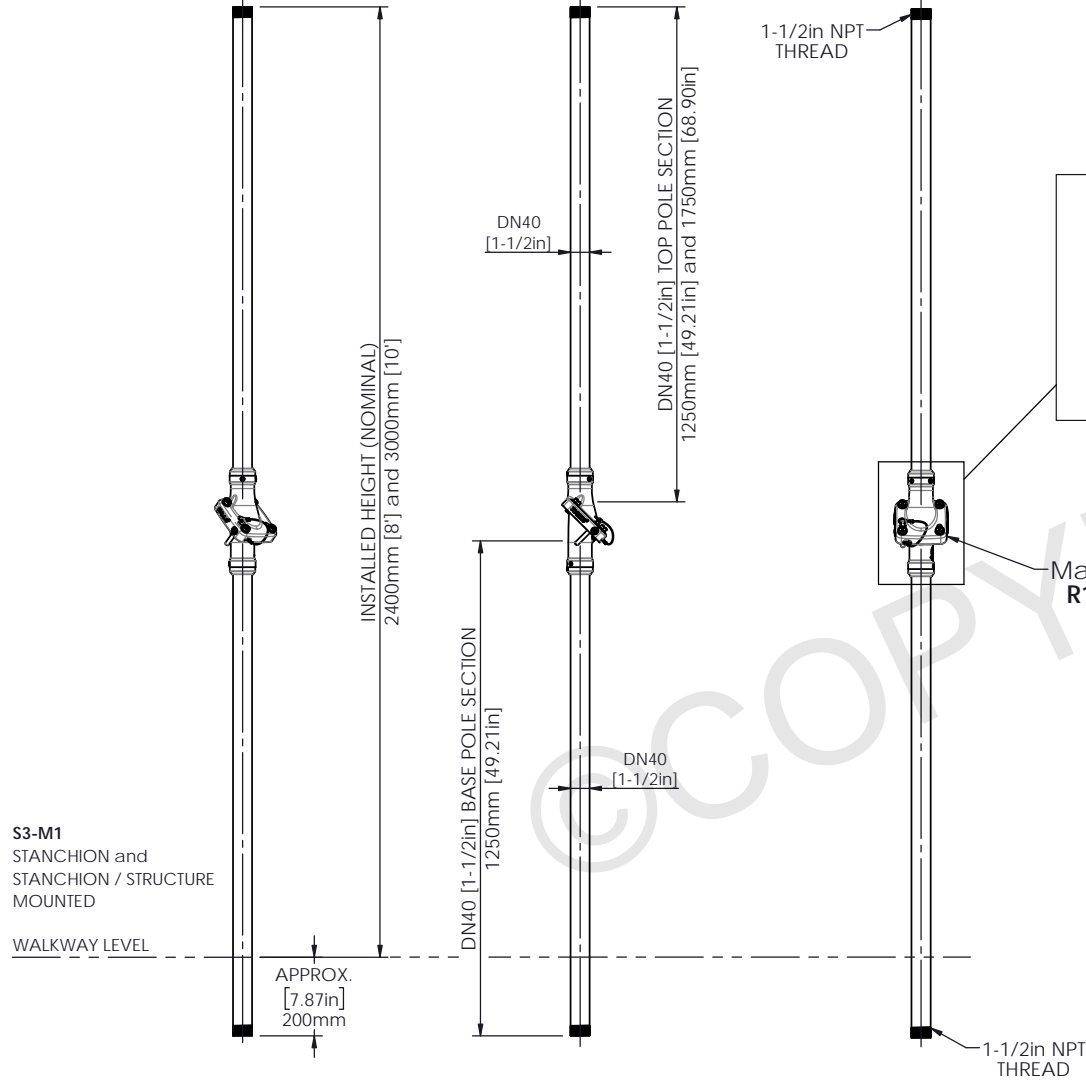

S3-M1 STANCHION MOUNTED
ASSEMBLY VIEW

S3-M1 STANCHION/STRUCTURE MOUNTED
ASSEMBLY VIEW

Ordering Information: ALUMINUM

| INSTALLED HEIGHT | PRODUCT CODE | WEIGHT |
|------------------|-----------------|-------------------|
| 2400mm [8'] | S3-M1-2400-T-AL | 9.0 kg (19.8 lb) |
| 3000mm [10'] | S3-M1-3000-T-AL | 10.0 kg (22.0 lb) |

Ordering Information: HOT-DIP GALVANIZED

| INSTALLED HEIGHT | PRODUCT CODE | WEIGHT |
|------------------|-----------------|-------------------|
| 2400mm [8'] | S3-M1-2400-T-HG | 14.4 kg (31.7 lb) |
| 3000mm [10'] | S3-M1-3000-T-HG | 16.4 kg (36.1 lb) |



Scan Code with QR Reader app for more Swivelpole™ Solutions

PATENTED PRODUCTS
www.maxisjoint.com

PATENTED PRODUCTS
www.swivelpole.com



This document is the property of and protected by copyright owned by Swivelpole Group Pty Ltd and/or Exemplar Products Pty Ltd. The designs and other information embodied in this document comprise confidential information of Swivelpole Group Pty Ltd and/or Exemplar Products Pty Ltd and form part of products covered by international patents and registered designs including US patent No 6957832 and US patent No 9945143. Unauthorised use, reproduction and disclosure are strictly prohibited. This document must not be removed from the premises of the licensed user of this document without Swivelpole Group Pty Ltd's and/or Exemplar Products Pty Ltd's prior approval.

ALL DIMENSIONS ARE IN MILLIMETERS / INCHES
SERIES / CODE: S
PART NUMBER: As Noted (RQ1845 - 26/02/23)

DRAWN BY: KM DATE: 12/3/20
CHECKED BY: BP DATE: 12/3/20
APPROVED BY: RP DATE: 12/3/20

TITLE: Swivelpole™ S3 - Maxis™ M1 Base Section - THREADED - Top Section - THREADED General Assembly

THIRD ANGLE PROJECTION
SCALE: N.T.S.
DRG No: C-NEC-S3-M1-4040-T-(HG-AL)
REV: 3
A3

NEC

STRUCTURALLY CERTIFIED

| ITEM NO. | QTY. | DESCRIPTION | MATERIAL OPTIONS |
|----------|------|------------------------------|---------------------|
| 1 | 1 | TOP POLE SECTION - THREADED | 316 STAINLESS STEEL |
| 2 | 1 | Maxis™ M1 Joint | 316 STAINLESS STEEL |
| 3 | 1 | BASE POLE SECTION - THREADED | 316 STAINLESS STEEL |

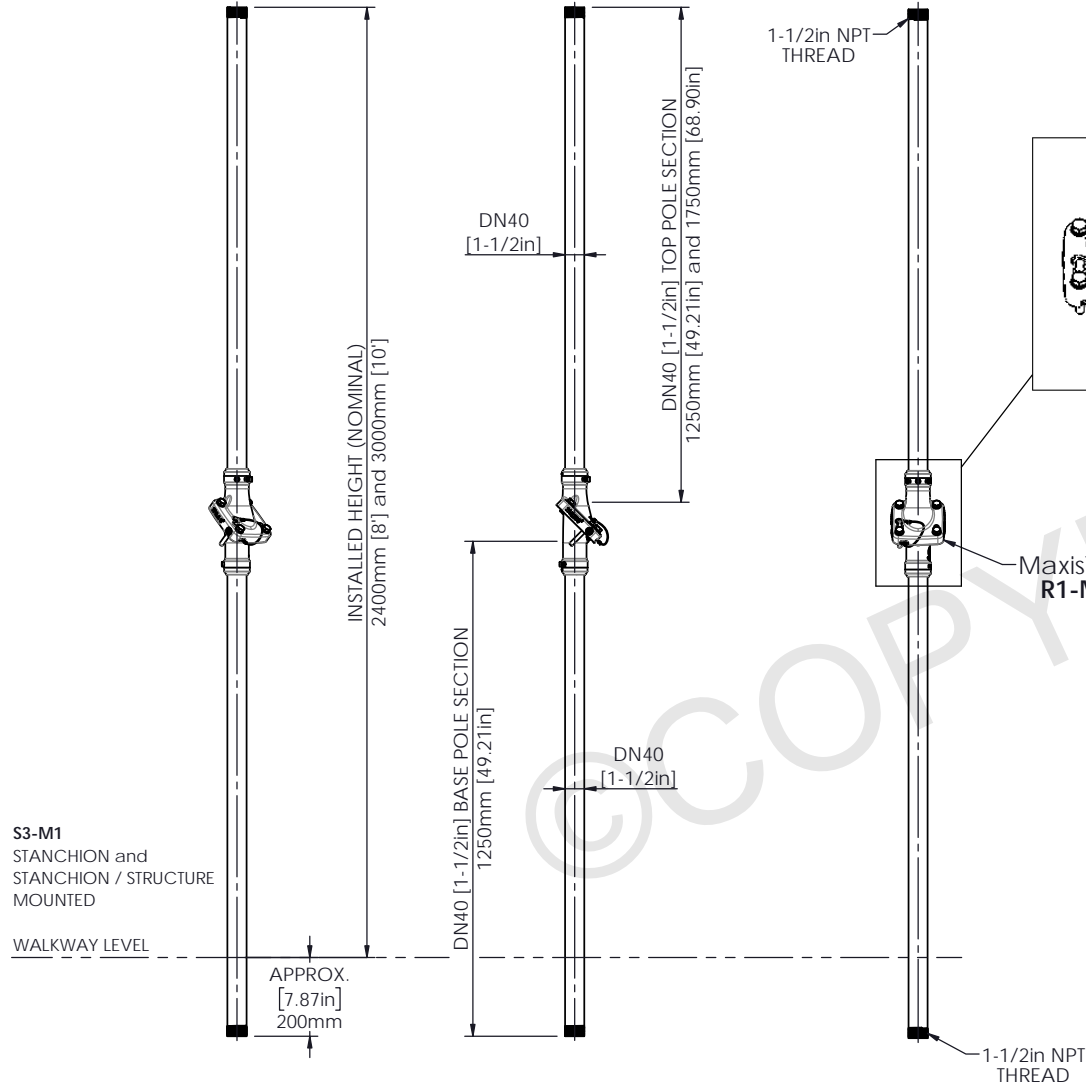

PIPE SECTIONS ARE INSERTED INTO Maxis™ JOINT

Maxis™ Part No: R1-M1-40-SS

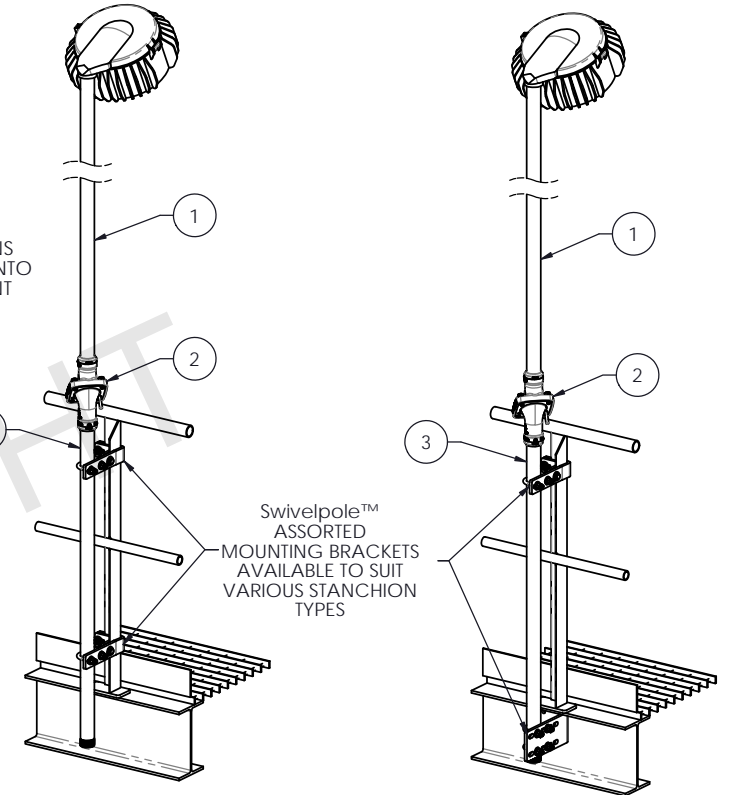

S3-M1 STANCHION MOUNTED ASSEMBLY VIEW

S3-M1 STANCHION/STRUCTURE MOUNTED ASSEMBLY VIEW

Ordering Information: 316 STAINLESS STEEL

| INSTALLED HEIGHT | PRODUCT CODE | WEIGHT |
|------------------|-----------------|-------------------|
| 2400mm [8'] | S3-M1-2400-T-SS | 15.0 kg (33.0 lb) |
| 3000mm [10'] | S3-M1-3000-T-SS | 17.1 kg (37.7 lb) |

S3-M1 STANCHION and STANCHION / STRUCTURE MOUNTED

WALKWAY LEVEL

NEC



Scan Code with QR Reader app for more Swivelpole™ Solutions

maxis
PATENTED PRODUCTS

www.maxisjoint.com

PATENTED PRODUCTS

www.swivelpole.com

Swivelpole™

This document is the property of and protected by copyright owned by Swivelpole Group Pty Ltd and/or Exemplar Products Pty Ltd. The designs and other information embodied in this document comprise confidential information of Swivelpole Group Pty Ltd and/or Exemplar Products Pty Ltd and form part of products covered by international patents and registered designs including US patent No 4957832 and US patent No 9945143. Unauthorised use, reproduction and disclosure are strictly prohibited. This document must not be removed from the premises of the licensed user of this document without Swivelpole Group Pty Ltd's and/or Exemplar Products Pty Ltd's prior approval. (RQ1843 - 26/02/23)

| ALL DIMENSIONS ARE IN MILLIMETERS / INCHES | SERIES / CODE | PART NUMBER |
|--|----------------|--|
| | S | As Noted |
| DRAWN BY: BP | DATE: 19/01/21 | TITLE: Swivelpole™ S3 - Maxis™ M1 |
| CHECKED BY: KM | DATE: 20/01/21 | Base Section - THREADED - Top Section - THREADED |
| APPROVED BY: RP | DATE: 20/01/21 | General Assembly |
| THIRD ANGLE PROJECTION | SCALE: N.T.S. | DRG No: C-NEC-S3-M1-4040-T-SS |
| | | REV 1 A3 |